

ORBIS DIRECT VENT ROOM HEATERS

CALORAMA/COMFORT VIEW SERIES DIRECT VENT WALL FURNACE
INSTALLATION AND OPERATING MANUAL



Complete instructions for safe installation, operation and servicing of units manufactured for use with natural gas and propane liquefied petroleum gases.



ORBIS COMFORTVIEW



ORBIS CALORAMA

ORBIS Calorama



WARNING: If the information in this manual is not followed exactly, a fire or explosion may result causing property damage, personal injury or loss of life.

- Do not store or use gasoline or other flammable vapors and liquids in the vicinity of this or any other appliance.
- **WHAT TO DO IF YOU SMELL GAS**
- Do not try to light any appliance.
- Do not touch any electrical switch; do not use any phone in your building.
- Immediately call your gas supplier from a neighbor's phone. Follow the gas supplier's instructions.
- If you cannot reach your gas supplier, call the fire department.
- Installation and service must be performed by a qualified installer, service agency or the gas supplier.

OWNER'S MANUAL

P/N CCV - MANUAL

CAUTION: Read these printed instructions prior to starting the installation of this unit

ATTENTION: Heaters installed in the State of Massachusetts must be installed by a licensed plumber or gas fitter.

IMPORTED BY:

The Gas Appliance Company, Inc.

FLORIDA, US of A

www.orbisheat.com

CALORAMA/COMFORT VIEW SERIES DIRECT VENT WALL FURNACE INSTALLATION AND OPERATING MANUAL

INDEX

SECTION I - Introduction and Safety Information	
Introduction	Page 2
Basic Description	Page 2
Qualified Service Agency	Page 2
Safety Rules	Page 3
Safety Information for Users of Propane / L.P. Gas	Page 4
Propane / L.P. Gas odor Warning	Page 5
CALORAMA/COMFORT VIEW (CCV) HEATER SPECIFICATIONS	Page 5
SECTION II – Installing Your Orbis (CCV) Direct Vent Space Heater	
Unpack the Heater	Page 6
Locating the Orbis Calorama/Comfort View Series Space Heaters	Page 6
Figure 1: Outside Clearances to the Vent Cap	Page 7
Figure 2: Clearances for Mounting the Heater Itself	Page 8
Table 2: Minimum Clearances Required for Mounting	Page 8
Mounting Template	Page 8
Figure 3: ALL MODELS – Unit Mounting Instructions	Page 9
Figure 4: Unit Mounting Template Position	Page 10
Figure 5: Wall Mounting Plate	Page 10
SECTION III - Vent, Wall Plate and Unit Installation	
Unpack the Vent Assembly	Page 11
Prepare for Installation	Page 11
Figure 6: Exploded Side View of Vent Installation	Page 11
Vent and Wall Plate Installation	Page 12
Figure 7: Vent Kit Assembly	Page 13
Figure 8: Vent Cap as seen from the Outside	Page 13
Connect Gas Piping	Page 14
Gas Supply	Page 14
Pressure Testing of the Gas Supply Piping System	Page 14
Figure 9: Guidelines for Gas Piping Connections	Page 15
Check for Gas Leaks	Page 15
Installing the Unit Cover	Page 16
Lighting the Unit	Page 16
Figure 10: Lighting Instructions	Page 16
Adjusting the Thermostat	Page 17
SECTION IV - Maintenance Instructions	
Maintenance Instructions (General)	Page 18
Maintenance Instructions for Calorama/Comfort View Series Heaters	Pages 18-20
Figure 11: Flame Pattern Calorama/Comfort View Series	Page 20
SECTION V - Troubleshooting Guide	Pages 21-23
SECTION VI - Replacement Parts Guide	Pages 24-25
SECTION VII - Limited Warranty	Pages 26-27
SECTION VIII - Blower Option	Pages 28-29

INTRODUCTION AND SAFETY INFORMATION

INTRODUCTION:

Your purchase of the ORBIS Calorama/Comfort View I, II or III gas fired direct vent wall furnace will reward you with many years of satisfying safe operation. Read these instructions carefully. If you cannot understand them, or do not feel comfortable installing this unit, contact a qualified service technician or your gas supplier for assistance.

BASIC DESCRIPTION:

Your direct vent wall furnace is shipped ready to install against an exterior wall up to 12" thick. For walls less than 12", the vent kit must be trimmed.

GENERAL SAFETY RULES

WARNING: READ THESE RULES AND THE INSTRUCTIONS CAREFULLY. FAILURE TO FOLLOW THESE RULES AND INSTRUCTIONS COULD CAUSE A MALFUNCTION OF THE FURNACE. THIS COULD RESULT IN DEATH, SERIOUS BODILY INJURY, AND/OR PROPERTY DAMAGE.

QUALIFIED SERVICE AGENCY:

A qualified service agency is defined as any individual, firm, corporation or company which either in person or through representatives, is engaged in and is responsible for: (1) the installation or replacement of gas piping or (2) the connection, installation, repair or servicing of equipment, who is experienced in such work, familiar with all precautions required, and has complied with all requirements of the authority/authorities having jurisdiction.

WARNING:

This unit is certified to ANSI Z21.86 (Most Recent Edition) Direct Vent Wall Furnace Standard (CAN 2-32M98) to provide safe, trouble free operation throughout the expected life of the unit. Any alteration, modification or adjustment not specifically mentioned in this owner's manual is NOT authorized by the manufacturer, distributor or certifying agency, and may result in the unsafe operation of this unit. Responsibility for these modifications rests solely with the individual or company who performed the change.

This unit must be installed in strict accordance with these instructions and all applicable local codes, if any. In the absence of local codes, refer to these instructions and National Fuel Gas Code, ANSI Z 223.1/Canadian Installation Code, CAN/CGA B149, and Combination Control Standards ANSI Z21.78, most current edition. This unit has been tested IAW (NFPA #54. These publications are available from the American National Standards Institute, 1430 Broadway, New York, NY 10018, or from the National Fire Protection Association, Batterymarch Park, Quincy, Mass., 02269. In Canada, refer to CAN/CGA-B149.1 (.2), Canadian Standards, most recent edition.

SAFETY RULES:

- 1) USE ONLY MANUFACTURER'S REPLACEMENT PARTS. Use of any other parts could cause injury or death.
- 2) Only specially modified and marked units are for use in a travel trailer, recreational vehicle or mobile home. A primary temperature limit control to limit the outlet air temperature is provided with each optional Mobile / Manufactured Home Installation Kit for installations in a travel trailer, recreational vehicle or mobile home.
- 3) MAINTAIN all clearances specified in the section entitled "Locating the Orbis Calorama/ Comfort View Series Heater." (See Fig. 1 and 2 and Table 2)
- 4) THIS APPLIANCE IS ONLY FOR USE WITH THE TYPE OF GAS INDICATED ON THE RATING PLATE. Be sure furnace is for type of gas to be supplied. Check the rating plate in the inside of the heater. Do not change the furnace to use other gases. Unsafe operation could result and could cause bodily injury and death.
- 5) Any safety screen, guard or parts removed for servicing the appliance must be replaced prior to operating the appliance to avoid property damage, bodily injury or death.
- 6) INSTALL the furnace to vent directly to the outdoors using only the vent assembly supplied with the unit, so that harmful gases will not gather inside of the building. (The vent kit part number for your unit can be found in the exploded parts view at the end of this manual)
- 7) NEVER vent flue gases into another room, a fireplace or any space inside a building.
- 8) NEVER test for gas leaks with an open flame.
- 9) ALLOW furnace to cool before servicing.
- 10) Children and adults should be alerted to the hazards of high, top output, surface temperatures and should stay away to avoid burns or possible clothing ignition.
- 11) Young children should be carefully supervised when they are in the same room as the furnace.
- 12) Clothing or other flammable material should not be placed on or near the appliance.
- 13) Do not lay any object on top of the heater that could obstruct the louvers of the unit through which warm circulating air needs to pass. DON'T allow children to insert articles in the louvers on the heater.
- 14) INSTALLATION AND REPAIR SHOULD BE DONE BY A QUALIFIED SERVICE PERSON. The appliance should be inspected before first use and at least annually by a qualified service person. More frequent cleaning may be required due to excessive lint from carpeting, bedding material, etc. It is imperative that control compartments, burners and circulating air passageways of the appliance be kept clean.

WARNING: DO NOT USE THIS HEATER IF ANY PART HAS BEEN UNDERWATER. IMMEDIATELY CALL A QUALIFIED SERVICE TECHNICIAN TO INSPECT THE APPLIANCE AND TO REPLACE ANY PART OF THE CONTROL SYSTEM AND ANY GAS CONTROL WHICH HAS BEEN UNDER WATER.

SAFETY INFORMATION FOR USERS OF PROPANE / L.P. GAS:

Propane/L.P. gas is highly flammable gas that can cause fire and explosions. Propane/L.P. gas is naturally odorless, but a special odorant is added to the gas to alert you to the presence of a gas leak, should one occur. This odor may fade over time. It is recommended that you obtain a "Scratch and Sniff" brochure to familiarize occupants with the odor associated with propane/LP gas. Not everyone is familiar with the safety precautions covering the use of Propane/L.P. gas. These precautions will help you safeguard your family and your property from an accident. Read the following carefully and make sure that everyone in your household knows the correct action to take in the event of a leak in the Propane/L.P. gas system.

IF YOU DO NOT UNDERSTAND THIS INFORMATION OR FEEL YOU NEED ADDITIONAL INFORMATION, CONTACT YOUR GAS SUPPLIER.

PROPANE / L.P. GAS ODOR WARNING

The odorant put into the Propane/L.P. gas by your gas supplier will allow you to detect the distinctive smell of gas in the event of a leak. If you smell propane / L.P. gas anywhere in or around your house or apartment, this odor indicates it is time to take immediate action in order to reduce or eliminate the risk of injury and or property damage.

KNOW AND MAKE SURE OTHERS IN YOUR HOUSEHOLD KNOW THE FOLLOWING PROCEDURES TO TAKE IN THE EVENT OF A PROPANE / L.P. GAS LEAK:

1. DO NOT operate electric switches, light matches, or use your telephone. Do not do anything that could create an open flame or sparks, resulting in the ignition of leaking gas.
2. USE a neighbor's telephone and call a qualified Propane / L.P. gas service technician or the gas supplier AND the fire department. Even if the odor of Propane / L.P. gas fades and you cannot detect the smell of gas, DO NOT turn on any appliances.
3. DO NOT re-enter the building or area until it has been declared safe to enter by the fire department or other authority. A properly trained and qualified Propane / L.P. gas service technician or gas supplier must repair the system leak and then re-light your gas appliances for you.

WARNING: IMPROPER INSTALLATION, ADJUSTMENT, ALTERATION, SERVICE OR MAINTENANCE CAN CAUSE INJURY OR PROPERTY DAMAGE: REFER TO THIS MANUAL. FOR ASSISTANCE OR ADDITIONAL INFORMATION, CONSULT A QUALIFIED INSTALLER, SERVICE AGENCY OR YOUR GAS SUPPLIER.

CALORAMA/COMFORT VIEW (CCV) SERIES HEATER SPECIFICATIONS

Model	CCVI Calorama/Comfort View I	CCVII Calorama/Comfort View II	CCVIII Calorama/Comfort View III
Maximum input BTU/h (KW)	8 000 (2,32)	15 000 (4,40)	20 000 (5,86)
Minimum input BTU/h (KW)	4 100 (1,20)	6 900 (2,00)	9 500 (2,78)
NATURAL GAS			
Manifold Gas Pressure:	4" (102 mm) wc	4" (102 mm) wc	4" (102 mm) wc
Minimum Gas Supply Pressure	5" (127 mm) wc	5" (127 mm) wc	5" (127 mm) wc
Maximum Gas Supply Pressure	7" (178 mm) wc	7" (178 mm) wc	7" (178 mm) wc
PROPANE/LP GAS *			
Manifold Gas Pressure:	10" (254 mm) wc	10" (254 mm) wc	10" (254 mm) wc
Minimum Gas Supply Pressure	11" (279 mm) wc	11" (279 mm) wc	11" (279 mm) wc
Maximum Gas Supply Pressure	13" (330 mm) wc	13" (330 mm) wc	13" (330 mm) wc
Gas Inlet Connection	3/8" NPT	3/8" NPT	3/8" NPT
Minimum Wall Thickness	2" (51 mm)	2" (51 mm)	2" (51 mm)
Maximum Wall Thickness	12" (305 mm)	12" (305 mm)	12" (305 mm)
Vent Opening Diameter in Wall	8,31" (211 mm)	8,31" (211 mm)	8,31" (211 mm)
Height of Unit	23,23" (590 mm)	23,23" (590 mm)	23,23" (590 mm)
Width of Unit	13,78" (350 mm)	19,69" (500 mm)	27,56" (700 mm)
Depth of Unit (including wall mounting Plate)	7,64" (194 mm)	7,87" (200 mm)	8,27" (210 mm)

Note: Minimum gas inlet gas pressure is for purpose of input adjustment.

* Exterior Regulator pressure MUST NOT EXCEED 13 IN. W.C.

SECTION II

INSTALLING YOUR ORBIS CALORAMA/COMFORT VIEW DIRECT VENT SPACE HEATER

UNPACK THE HEATER:

Unpack the unit from the carton. Remove the plastic bag. Examine all packing material looking for loose parts before discarding.

Loosen the two (2) bolts on the right and left bottom rear of the unit front cover only 2 or 3 turns (without removing them).

Remove the two (2) screws on top rear of the unit front cover, pull the top of the front cover away from the unit about an inch and lift it to take it off.

Remove the wall mounting plate from the unit by removing the [two (2) hexagonal nuts Calorama/Comfort View I or four (4) hexagonal nuts Calorama/Comfort View II & III] inside the back cover and keep them for securing the unit back to the same plate during installation.

LOCATING THE ORBIS CALORAMA/COMFORT VIEW SERIES SPACE HEATERS:

When choosing a location for your ORBIS Calorama/Comfort View Series Direct Vent Wall Furnace, please remember that the Vent Kit supplied with the unit must be installed WITHOUT alteration, with the exception of cutting the vent tubes to length, as directed in these instructions. In addition, the finished vent cap must be located as shown in Figure 1 (below). The bottom of the vent cap AFTER installation must be at least 12" (305mm) above ground level, on the outside wall.

After picking a location that meets the requirements, inspect the wall, floor and outside areas. Make sure there are no pipes, wiring, or anything else that would interfere with furnace or vent installation, if required, move them or pick a new location. The correct clearances for mounting the heater are shown in the illustrations below (Figure 2 and Table 2). Allow adequate accessibility clearances for servicing the unit.

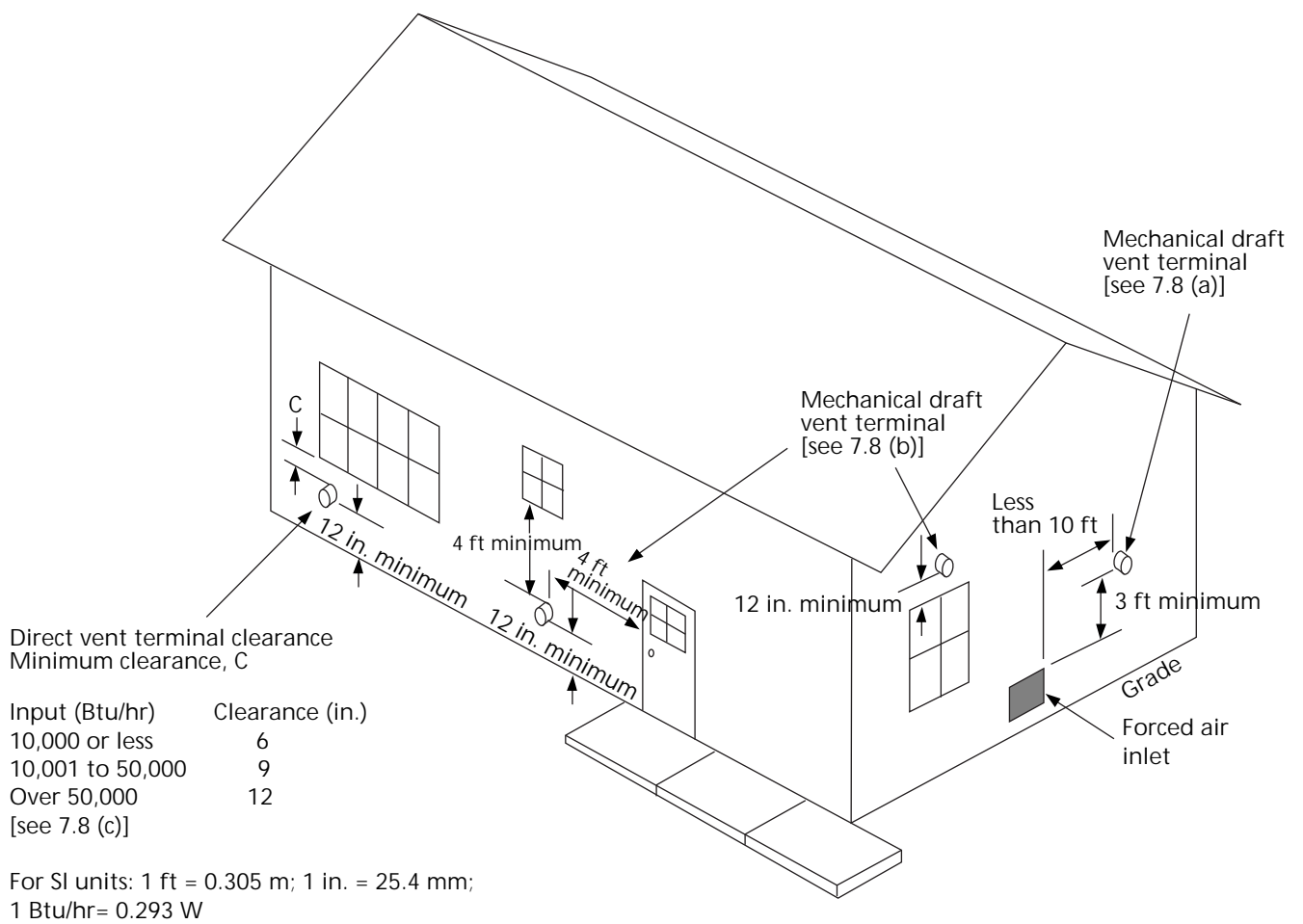

Figure 1: Outside Clearances to the Vent Cap per ANSI Z223.1-98

WARNING: The nearest point of the vent cap must be a minimum horizontal distance of 6 FEET (1.83 m) from any gas pressure regulator or gas meter (with the exception of the pressure regulator provided with this unit).

DUE TO HIGH OUTPUT TEMPERATURES AT THE TOP OF THE UNIT,
THE UNIT SHOULD BE LOCATED OUT OF TRAFFIC AND AWAY FROM DRAPERIES.

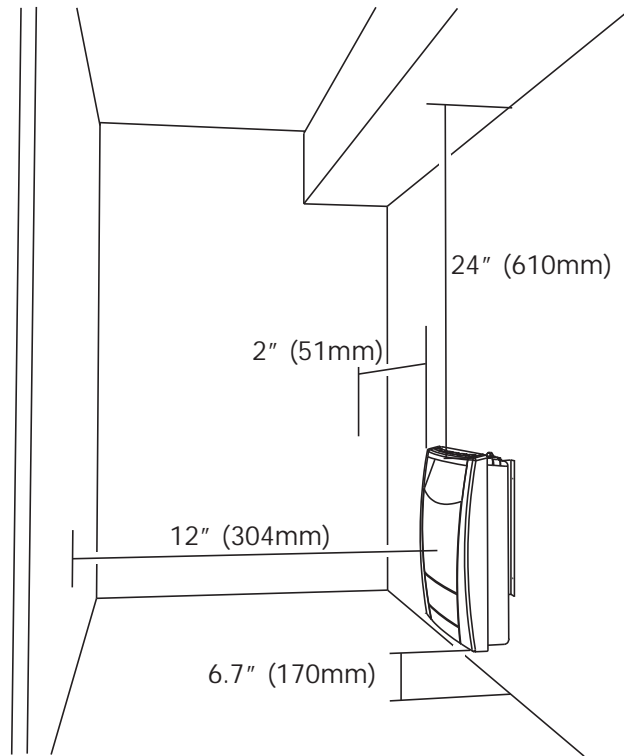

Figure 2: Clearances for Mounting the Heater Itself

TABLE 2
MINIMUM CLEARANCES REQUIRED FOR MOUNTING

Model	ALL CALORAMA/COMFORT VIEW SERIES UNITS
Distance from Sides of Unit	2" (51 mm)
Back of Unit	0" (0 mm)
Distance from Front of Unit	12" (304 mm)
Distance from Top of Unit	24" (610 mm)
Distance to Floor or Floor Materials (Carpeting, tile, etc.)	6,7" (170 mm)

Mounting Template:

A template is furnished in the carton with the unit (See Figure 3). The template illustrates all of the openings and mounting holes and their correct location for EACH UNIT. The illustration (Figure 3) gives you the required dimensional information for mounting the unit, in the event that the template is unusable or lost. The heater has to be mounted on the wall with the special wall mounting plate provided (See Figure 5). The template

must be located so that the ORBIS Calorama/Comfort View Series Heater is installed BETWEEN THE WALL STUDS (See Figure 4). It is NOT permissible to cut the wall studs in order to install this unit. The wall studs can be used to mount the Calorama/Comfort View II and Calorama/Comfort View III units to the wall in order to provide a secure installation. The template is to be located directly on the floor surface or floor covering such as carpeting or tile to provide the correct clearances from the bottom of the unit to combustible materials. NEVER reduce the clearances from the finished unit to adjacent combustible materials.

Figure 3: ALL MODELS – Unit Mounting Instructions

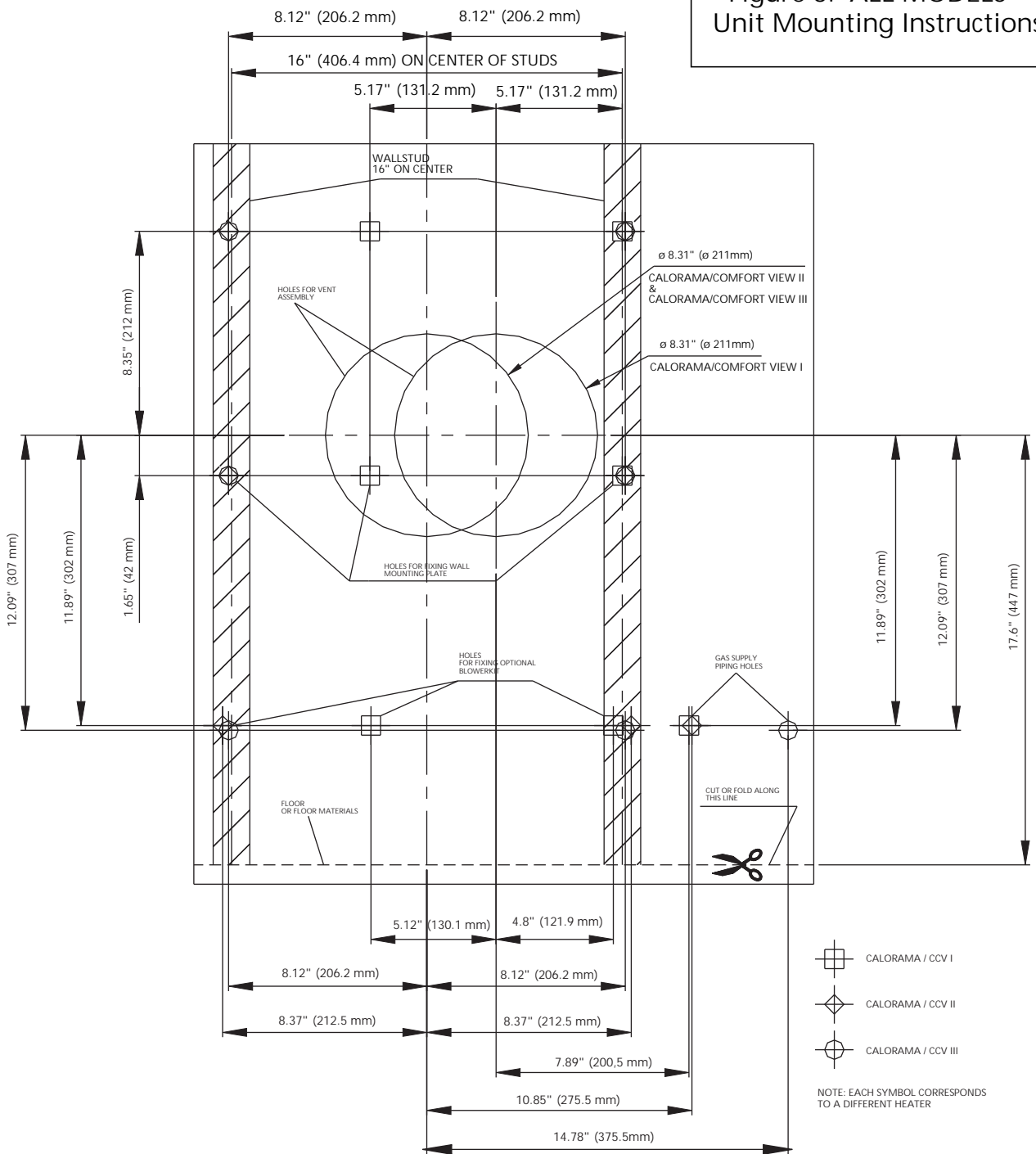

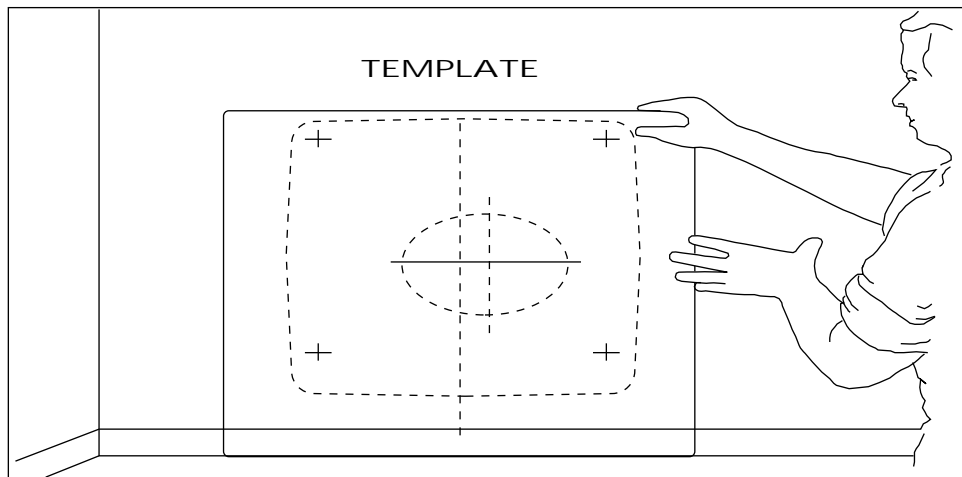

Figure 4: Unit Mounting Template Position

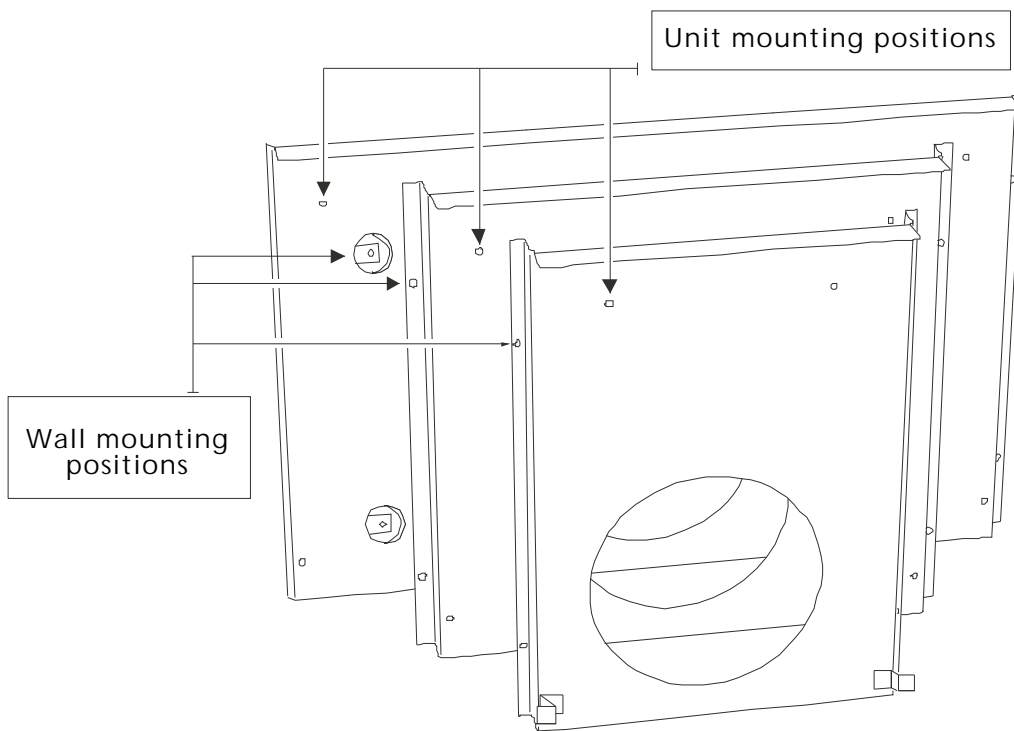

Figure 5: Wall Mounting Plate (ALL MODELS)

SECTION III

VENT, WALL PLATE AND UNIT INSTALLATION

Unpack the Vent Assembly:

Inside the heater's carton you will find the following parts which make up the vent kit: one (1) exhaust gas pipe, one (1) air inlet pipe, one (1) protection vent pipe, one (1) vent cap, one (1) vent cap flange ring, six (6) screws

During installation, the underside of the flange on the vent cap assembly has a lip that can be filled with sealant to prevent rainwater or small insects from entering the structure from outside. This appliance is certified for installation on walls that are a minimum of 2" (51mm), and a maximum of 12" (305 mm) thick. The vent kit supplied will accommodate walls up to a 12" (305 mm) thickness. The vent kit uses slip-fit connections to the heat exchanger (flue terminus) and does not require caulking. IT CANNOT BE CONNECTED TO ANY OTHER TYPE OF FLUE SYSTEM. The flow of combustion and ventilation air must NEVER be obstructed.

Prepare for Installation:

After ensuring that the location you have selected for the installation complies with the requirements outlined in this manual in the section titled "Locating the Orbis Calorama/Comfort View Series Space Heater," you should check to see that you have all of the following required tools to complete the job : Tape measure Carpenter's level Drill Screwdriver (Phillips & Standard) Jig Saw Hole Cutter Metal Cutting Shears Outdoor Caulking Pipe Joint Compound 7/16" (11mm) Socket Tool 9/32" (7mm) Wrench Soapy water solution to check for leaks 3 vent kit wall fasteners and 4 unit wall mounting plate fasteners

Refer to the following illustration (Fig 6) for an exploded side view of the installation.

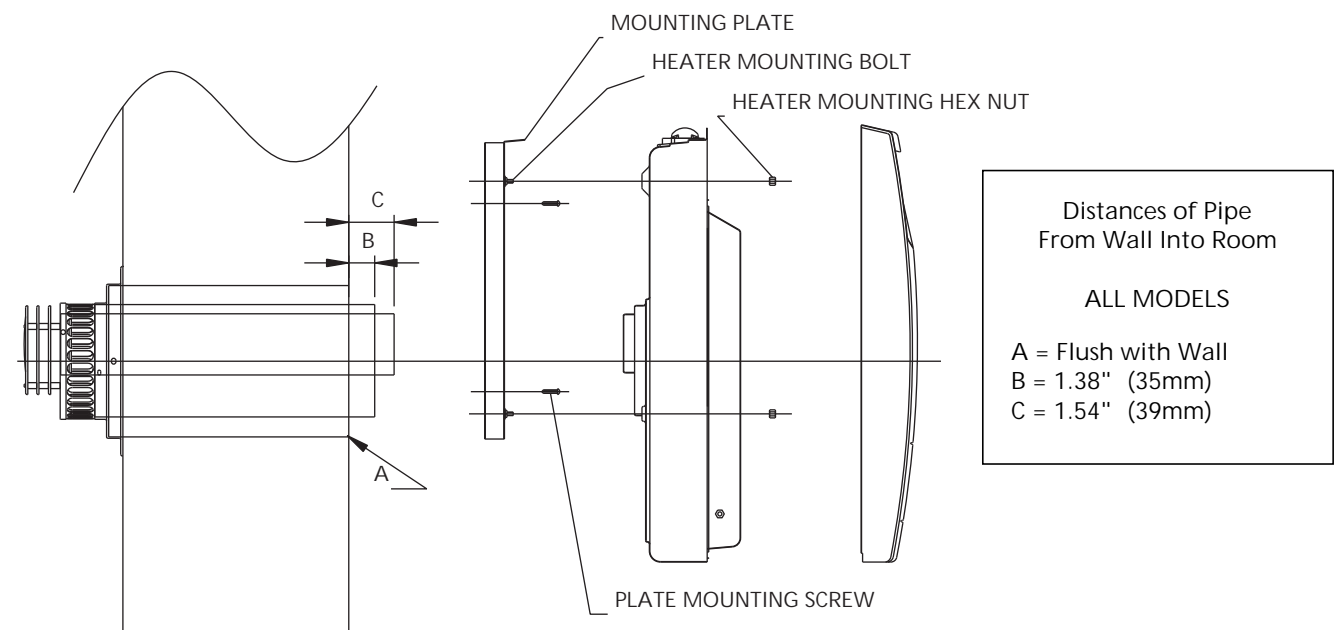

Protection Vent Pipe (A) is Cut Flush To the Inside Wall

Figure 6: Exploded Side View of the Finished Installation

Begin installation by locating the wall studs on the inside wall of the structure. Use a stud locator or small finishing nail (repeatedly drive and remove a nail into the wall in the area of the stud until you find it). After you have found one stud, the inside edge of the other stud should be about 14 _ " from the one found. The studs will be about 1 1/2" (39mm) wide. Using a level, draw vertical lines that will represent the two stud centers.

Vent and Wall Plate Installation:

Step 1 Place the supplied (paper) template at the desired inside wall location with the template bottom resting on the floor (See Fig. 4). The mounting template large diameter hole MUST be between the wall studs.

Step 2 Mark the location of all the holes corresponding to your unit: The large 8.31" (211mm) opening, the holes for the wall mounting plate supporting screws (4 holes) and for the gas supply piping. (See Fig. 3 for the correct dimensions for these openings if the template is lost or not usable)

Step 3 Cut the marked large diameter opening corresponding to your unit through the inside and outside walls. Ensure that this opening is large enough to allow the vent protection pipe to pass through without bending. In addition, make sure that the holes in the inside and outside wall are concentric to one another. NOTE: Cut the outside hole slightly lower (not more than 1/8") than the inside hole so that the vent will have a slight downward slope toward the outside. This will help prevent water from entering. Mark the four (4) holes corresponding to your unit's mounting plate. Drill the hole for the gas supply piping with an appropriate drill size for the piping.

Step 4 Determine the overall wall thickness, (from the outside wall up to the inside wall). Cut the three vent pipes to the following lengths with a sheet metal cutting scissors:
Exhaust pipe: overall wall thickness plus 4.84" (123 mm).
Air inlet pipe: overall wall thickness plus 2.87" (73 mm). Cut off from the side opposite to the one with the holes.
Protection vent pipe: overall wall thickness plus 0.76" (19.2 mm). Cut off from the side opposite to the one with the holes Assemble the vent flange ring on the protection pipe and secure with three (3) screws supplied. (The screws must project inside the pipe). Insert the air inlet pipe into the flange ring bore, insert the cap on the air inlet pipe and align the holes on the three parts. Secure with three (3) screws supplied. (The screws must project inside the air inlet pipe). Figure 7 shows the vent kit assembly.

INSIDE DIAMETERS	CCV I	CCV II	CCV III
EXHAUST PIPE	3,19" (81mm)	3,19" (81mm)	3,98" (101mm)
AIR INLET PIPE	5,91" (150mm)	5,91" (150mm)	6,79" (172,5mm)
PROTECTION PIPE	7,99" (203mm)	7,99" (203mm)	7,99" (203mm)

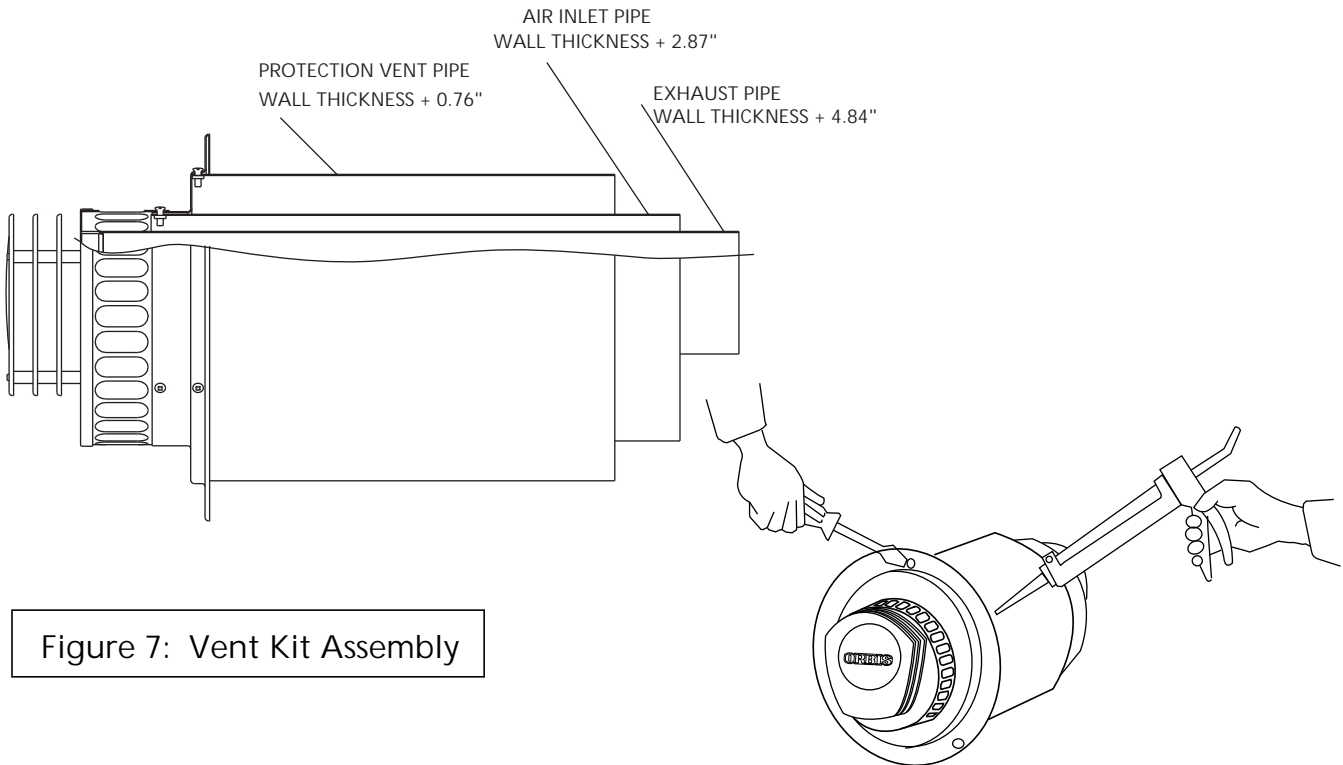

Figure 7: Vent Kit Assembly

Figure 8: Vent Cap "ORBIS" Marking is Upright and Level

Step 5 Insert the vent kit assembly through the outside hole into the inside of the structure. Ensure that the "ORBIS" lettering on the vent cap is level and upright. (See Figure 8).

Fix the vent assembly to the outside wall with three (3) screws (not provided) and apply caulking to the wall at the vent assembly/wall contact location (See Figure 8).

Step 6 Install the wall mounting plate on the inside wall using the protruding vent pipe to center the wall plate vent opening. Fix the wall plate to the wall using four (4) screws, drywall fasteners or molly screws as appropriate to support the weight of the unit. Place the unit on the wall mounting plate, taking extreme care to ensure that the exhaust vent pipe in the vent cap is securely engaged with the similar sized opening in the rear of the unit. Make sure the exhaust vent pipe remains engaged in its position in the vent cap. The air inlet pipe must also slide over its corresponding vent connection.

After the wall mounting plate has been fixed to the wall as directed above, mount the unit on the plate sliding it onto the corresponding bolts protruding from the plate. Secure the heater to the mounting plate with the two (2) or four (4) hexagonal nuts set apart during the unpacking of the furnace.

Connect Gas Piping:

Connect the gas piping to the gas inlet of the valve on the right side of the unit. Gas piping connections require an approved pipe joint compound that must resist the action of Natural and Propane/LP Gas. Please refer to the cautionary remarks noted at the beginning of this manual. If local codes permit the use of a flexible metal gas connector, it must be of the type approved for this use by displaying a certification symbol in accordance with ANSI Z21.24 (Most Current Edition) covering Appliance Connectors or Corrugated Metal Tubing and Fittings;

- OR -

If local codes permit the use of flexible gas connector of other than all-metal construction, it must be of the type approved for this use by displaying a certification symbol in accordance with ANSI Z21.45 (Most Current Edition) covering Assembled Flexible Appliance Connectors of other than All-Metal Construction.

Gas Supply:

The template (See Figure 3) supplied with your unit shows a recommended location for the gas supply piping. Gas piping must be installed in accordance with all applicable building and plumbing codes. For Propane Units., Gas supply Line Pressure MUST NOT EXCEED 13 IN. W.C..It is recommended that a gas shut off valve be installed upstream of the heating unit, even if local codes do not require it. It is recommended that a sediment trap or "drip leg" be installed in the gas piping just before the piping enters the unit. (See Figure 9). Refer to the most current edition of the National Fuel Gas Code, ANSI Z223.1 (Most Recent Edition), for details on gas piping installation.

Pressure Testing of the Gas Supply Piping System:

Test of gas supply piping system at pressures in excess of _PSIG (3.5 kPa):

When carrying out tests at this range of pressures, the appliance and its appliance main gas valve must be disconnected from the gas supply piping system.

Tests of gas supply piping system at pressures equal to or less than _ PSIG (3.5 kPa):

When carrying out tests at this range of pressures, the appliance must be isolated from the gas supply piping system by closing the shut off valve if it has been installed upstream the heater. Otherwise, the appliance and its appliance main gas valve must be disconnected from the gas supply piping system. (See figure 9).

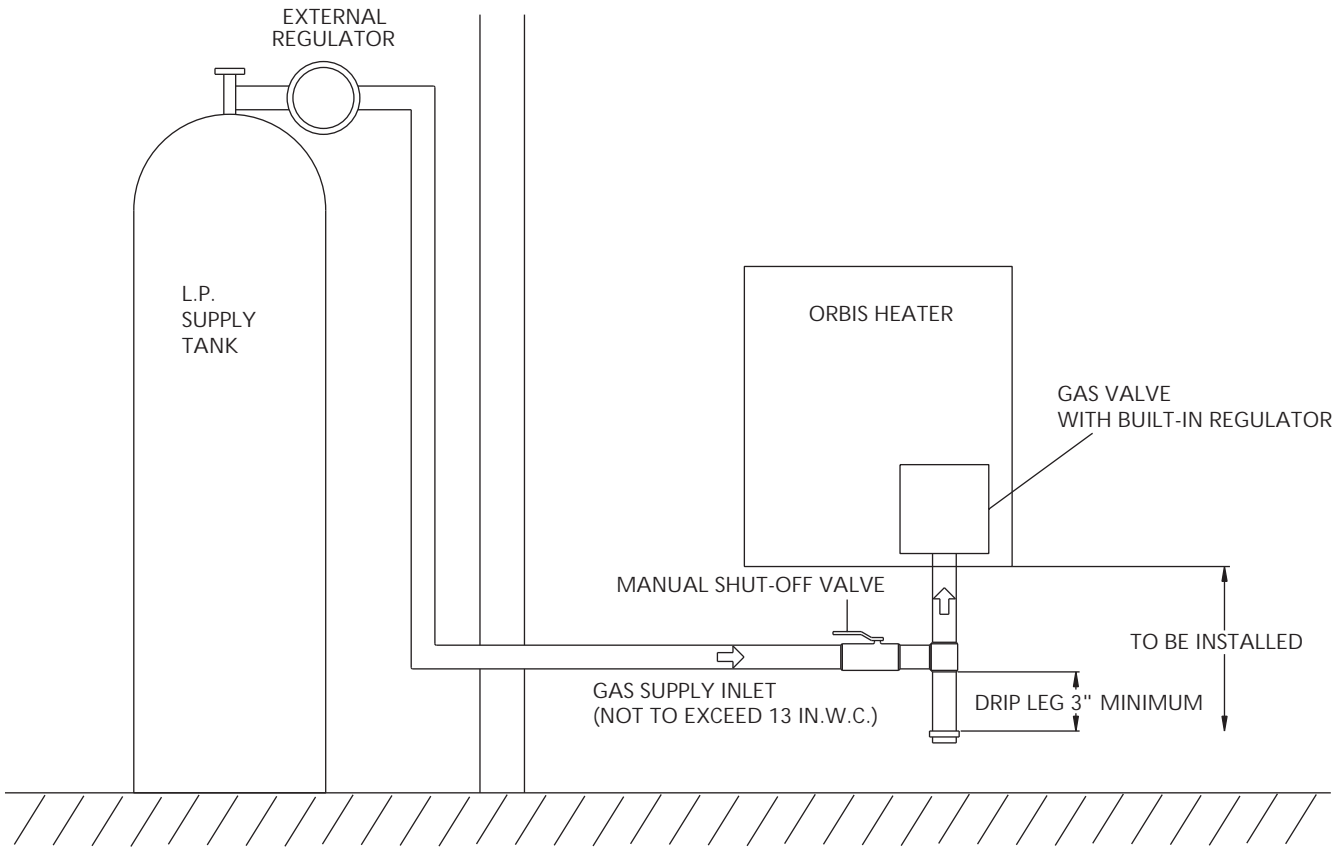

Fig 9 – Guidelines for Gas Piping Connections (ANSI Z223.1)

Check for Gas Leaks:

After connecting the gas supply piping to the gas control on the heater, the connections must be checked thoroughly for leaks. With the shut-off valve on the supply piping near the heater (if installed) turned ON, but the gas control knob supplied with the heater OFF, apply liberal amounts of a soapy water solution to all of the piping joints. A gas leak will cause bubbles to form. Note any leaks in the piping system. Shut off the gas at the shut-off valve (if installed), or at the gas meter of the Propane/LP tank serving the structure. Fix the leaking joint and re-test the joints as directed above.

WARNING: NEVER USE A MATCH OR OPEN FLAME TO TEST FOR LEAKS. THIS CAN CAUSE PROPERTY DAMAGE, BODILY INJURY OR DEATH.

Installing the Unit Cover:

Slide the heads of the two (2) bolts at the bottom of the front cover into the corresponding holes in the back cover (with the upper end of the front cover leaning about an inch forward), push the front cover in and down until the bolts lock into place. Slide the overhangs at the upper end of the front cover under the back cover and fix with the two (2) screws.

Secure the two (2) bolts at the bottom of the front cover.

Lighting the Unit:

The pilot and main burner lighting instructions for this unit can be found as a full size label which is attached to a plate of sheet metal which hangs on a chain at the rear of the heating unit. The instructions can also be found at Figure 10 below. These instructions will direct you through the complete safe lighting and operation of the gas control system.

FOR YOUR SAFETY READ BEFORE LIGHTING

WARNING: If you do not follow these instructions exactly, a fire or explosion may result causing property damage, personal injury or loss of life.

A. This appliance has a pilot which must be lighted by hand.
When lighting the pilot, follow these instructions exactly.

B. BEFORE LIGHTING smell all around the appliance area for gas.
Be sure to smell next to the floor because some gas is heavier than air and will settle on the floor.

WHAT TO DO IF YOU SMELL GAS:
* Do not try to light any appliance.
* Do not touch any electric switch; do not use any phone in your building.
* Immediately call your gas supplier from a neighbor's phone.
Follow the gas supplier's instructions.

* If you cannot reach your gas supplier, call the fire department.

C. Use only your hand to push in or turn the gas control knob. Never use tools. If the knob will not push in or turn by hand, don't try to repair it; call qualified service technician. Force or attempted repair may result in a fire or explosion.

D. Do not use this appliance if any part has been under water. Immediately call a qualified service technician to inspect the appliance and to replace any part of the control system and any gas control which has been under water.

LIGHTING INSTRUCTIONS

- STOP: Read the safety information above on this label.
- Turn gas control knob clockwise to "OFF".
- Wait five (5) minutes to clear out any gas. Then smell for gas, including near the floor. If you smell gas, STOP! Follow "B" in the safety information above on this label. If you don't smell gas, go to the next step.
- Find pilot by looking through the upper Heat exchanger window of the heater.

- Turn gas control knob counterclockwise to "PILOT".
- Push in the control knob all the way and hold in 90 seconds. Then light the pilot with the piezoelectric igniter (black knob) several times if necessary, until it is lit. Continue to hold the control knob in for about one (1) minute after the pilot is lit. Release the knob and it will pop back up. Pilot should remain lit; if it goes out, repeat steps 1 through 6.
- Replace the front panel (if removed)
- Turn gas control knob counterclockwise to the desired temperature setting.

IGNITER BUTTON
PILOT
GAS CONTROL KNOB SHOWN IN "OFF" POSITION
"LO"
"HI"
THERMOCOUPLE
PILOT
ELECTRODE CERAMIC

TO TURN OFF GAS TO APPLIANCE

Turn gas control clockwise to the "OFF" position. Do not force.

**DUE TO HIGH SURFACE TEMPERATURES, KEEP CHILDREN, CLOTHING, AND FURNITURE AWAY.
KEEP BURNER AND CONTROL COMPARTMENT CLEAN.
SEE INSTALLATION AND OPERATING INSTRUCTIONS ACCOMPANYING APPLIANCE.**

Figure 10: lighting Instructions

WARNING: DO NOT OPERATE THIS APPLIANCE WITH THE PILOT/MAIN BURNER OBSERVATION PANELS REMOVED, CRACKED OR BROKEN. REPLACEMENT OF THESE PANELS SHOULD BE DONE BY A LICENSED OR QUALIFIED PERSON.

NEVER OPERATE YOUR ORBIS CALORAMA/COMFORT VIEW SERIES HEATER WITH THE FRONT COVER REMOVED. THIS APPLIANCE GENERATES HEAT AND THE INNER PANELS, WHEN EXPOSED, CAN CAUSE SEVERE BURNS AND/OR PROPERTY DAMAGE.

Adjusting the Thermostat:

The Orbis Calorama/Comfort View Series heater is equipped with a modulating thermostatic control for your comfort. The term "modulating" means that the gas flow to the burner is constantly adjusted either higher or lower depending on the temperature of the room. Position LO on the thermostat dial is the lowest temperature setting. Position HI on the thermostat dial is the highest temperature setting. Choose the setting that provides the most comfort for you. Excessively high temperature settings can cause you to constantly readjust the thermostat and lose valuable efficiency.

CARE OF YOUR UNIT: This unit needs very little care.
To clean the outer case, wipe it with a soft damp cloth. DO NOT USE SOLVENTS.

SECTION IV

MAINTENANCE INSTRUCTIONS

Maintenance Instructions (General):

As with all fuel burning appliances, it is important to conduct periodic maintenance functions that will allow for continued safe, efficient operation of the unit. We suggest that before each heating season, or at least once every year, you conduct the following MINIMUM service functions.

WARNING: THE FOLLOWING INSTRUCTIONS ARE DESIGNED TO DIRECT A QUALIFIED SERVICE TECHNICIAN THROUGH THE PROPER PERIODIC MAINTENANCE AND REPAIR PROCEDURES WHICH MAY BE REQUIRED THROUGHOUT THE EXPECTED LIFE OF THIS UNIT. NO ATTEMPT SHOULD BE MADE BY THE HOME OWNER TO CARRY OUT THESE FUNCTIONS.

Maintenance Instructions for All Calorama/Comfort View Series Heaters:

Step 1 The gas supply should be turned OFF at the shut-off valve in the supply line leading to the appliance (if supplied), or at the gas source. The gas to the unit should be disconnected so the unit can be removed from the wall.

Step 2 Remove the front cover, loosen the two (2) bolts on the bottom right and left rear of the unit 2 or 3 turns (without removing them). Remove the two (2) screws on top of the unit, pull the front cover forward about an inch and lift it to take it off.

Step 3 Remove the Calorama/Comfort View unit from the wall mounting plate by removing the hexagonal nuts (Two (2) nuts for Calorama/Comfort View I or four (4) nuts for Calorama/Comfort View II and III) inside the back cover.

Step 4 Carefully examine the interior of the vent pipe. If you notice any blockage or obstruction that was not part of the unit when it was installed, clean the pipes and prepare them for the reattachment to the unit.

Step 5 Look inside the openings of the rear of the unit and check for foreign materials. Remove any objects which may block or obstruct the free flow of combustion and ventilation air. You will only be able to see a portion of the interior of the unit from this angle.

IMPORTANT COMFORT VIEW NOTICE: Do not remove the heat exchanger front glass when carrying out the periodic maintenance check or servicing the unit.

Step 6 Visually check the pilot and the main burner for signs of excessive dirt and debris through the heat exchanger front glass on Comfort View units or through the pilot viewing window located at the top right front of the heat exchanger on Calorama units. If you find any of these, follow the directions below to reach the components to clean, otherwise continue to Step 7:

Remove the gas control valve rod by removing the cotter pin. Disconnect both piezoelectric igniter cables from their connections to the heat exchanger. Remove the electrode ceramic. Remove the two (2) gas lines connecting the gas control valve to the pilot and main burner from both ends. Remove the thermocouple from both ends. Remove the gas control valve grip (one (1) screw) and remove the valve. Remove the gas control valve support (two (2) screws). Remove the sheet metal valve protector (two (2) screws). Remove the main burner fixing nut on the left of the heat exchanger. Remove the main burner support (four (4) screws). Take the main burner assembly (with pilot attached) out of the heat exchanger. Clean the pilot and main burner completely as necessary with a soft bristled brush.

Check the main burner gasket , If it is damaged or worn replace with a new gasket available from your dealer. (the gasket part number can be found in the exploded parts view at the end of this manual) After cleaning, reinstall the main burner module in the reverse order of the directions above.

Step 7 Replace the heater on the wall mounting plate. Take extreme care to ensure that the EXHAUST pipe is firmly engaged with the vent outlet at the rear of the heater. Be sure that the pipe remains engaged in its position in the vent cap. The air inlet pipe must slide over its appropriate opening. Use the hexagonal nuts of step 3 above to firmly re-attach the unit back on the wall mounting plate.

Step 8 Reconnect the gas supply. Perform the leak test procedure found in the section of this manual titled "Check for Gas Leaks" on page 14.

CONDUCT ALL LEAK TESTING ONLY IN A WELL VENTILATED AREA.
THE AREA MUST BE FREE OF ACCUMULATED GAS. BE SURE YOU DO NOT SMELL ANY
GAS BEFORE PROCEEDING TO OPERATE THE UNIT.

Step 9 Verify Proper Operation After Servicing: Place the unit back into operation following the procedures found on the hanging tag behind the unit and/or in Figure 10 in this manual. Check all connections from the Gas Control Assembly to the pilot and main burner with soapy water solution. Bubbles on any of the joints indicate a leak is present and must be repaired. Turn OFF the gas to the unit when performing repairs to the gas piping system. Check to make sure that the spark ignition (piezoelectric igniter) lights the pilot.

Step 10 While the main burner is ON, check the flames to see that they are burning a clean blue color.

Note: After cleaning, the first few minutes of heater operation will probably have some yellowish flying traces in the flame due to the burning of particles left behind during the cleaning operation.

Liquid propane has some evidence of yellowing in the tips of the flame. The main burner and pilot flames can be observed through the heat exchanger front glass on Comfort View units or through the pilot viewing window located at the top right front of the heat exchanger on Calorama units. See Figure 11 below for an approximation of the correct flame patterns. If your unit is not burning cleanly, turn it OFF. Clean or change injectors following the directions below.

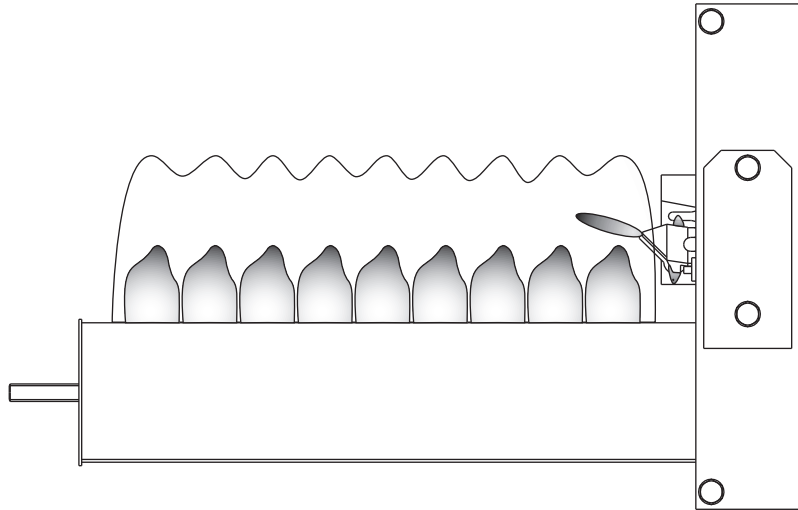

Figure 11: Flame Pattern for Pilot and Main Burner

TO CLEAN OR CHANGE THE INJECTORS

Remove the two (2) gas lines connecting the gas control valve to the pilot and main burner from both ends. Remove the main burner injector and the pilot injector. Clean the injectors with a soft bristled brush and air. Reinstall both injectors and replace the two (2) gas lines.

IMPORTANT NOTICE: Do not use any sharp or hard tool to clean the injectors as their calibrated holes may become damaged.

Step 11 Slide the heads of the two (2) bolts at the bottom of the front cover into the corresponding holes in the back cover (with the upper end of the front cover leaning about an inch forward), push the front cover in and down until the bolts lock into place. Slide the overhangs at the upper end of the front cover under the back cover and fix with the two (2) screws. Tighten the two (2) bolts at the bottom of the front cover.

Before completing your periodic maintenance check, ensure that the heater area is kept clear and free from combustible materials, gasoline and other flammable vapors and liquids. Also, check to see that the flow of combustion and ventilation air around the vent cap on the outside of the structure is not obstructed.

**USE ONLY FACTORY AUTHORIZED REPLACEMENT PARTS!
SUBSTITUTION CAN CAUSE IMPROPER OPERATION, INJURY,
DEATH AND/OR PROPERTY DAMAGE.**

SECTION V

ORBIS CALORAMA/COMFORT VIEW (CCV) HEATER TROUBLESHOOTING GUIDE

SYMPTOM	POSSIBLE CAUSE	SOLUTION
Smoke or strange smell on the first trial light up after installation.	<ol style="list-style-type: none"> 1. Grease or oil on the heat exchanger. 2. Dust on heat exchanger. 	<ol style="list-style-type: none"> 1. No action required: will stop after a short period of operation. 2. Apply maintenance procedures (see SECTION IV of this manual).
Sharp clicking noises at ignition, or when the unit cuts down or goes out.	<ol style="list-style-type: none"> 1. Expansion/contraction noise. 	<ol style="list-style-type: none"> 1. No action required: heater activity causes some minor noises.
Steam is discharged from the outside vent.	<ol style="list-style-type: none"> 1. Water condensation on cold days. 	<ol style="list-style-type: none"> 1. No action required: this is a natural result of combustion.
Pilot will not light.	<ol style="list-style-type: none"> 1. Gas is not turned on. 2. Piezo ignitor (electrode) is damaged or wire lead is loose. 3. Pilot orifice is clogged. 4. Gas Control knob not set properly. 5. Improper gas supply. 	<ol style="list-style-type: none"> 1. Turn on the gas at the manual gas valve or main gas line. 2. Apply maintenance procedures (see SECTION IV of this manual) or replace Piezo ignitor (electrode) 3. Apply maintenance procedures (see SECTION IV of this manual) 4. Review correct lighting procedures (see Figure 10 on page 15). 5. Call your gas supplier.

SYMPTOM	POSSIBLE CAUSE	SOLUTION
Pilot will not stay lit.	<ol style="list-style-type: none"> 1. Gas control knob did not pop up. 2. Thermocouple not functioning. 3. Heater is still hot from previous operation 	<ol style="list-style-type: none"> 1. Check the position of the knob in the frame. Remove front cover and check movement of the gas control rod. Gas control valve may be jammed – replace as needed. 2. Check thermocouple connection and that position is in the center of the pilot flame tip. Replace as necessary. 3. Wait 5 minutes to allow the heater to cool down, then relight.
Main burner won't light.	<ol style="list-style-type: none"> 1. Gas control knob turned to "PLT" position. 2. Thermostat turned too low. 3. Gas supply piping too small. 4. Defective gas control valve. 	<ol style="list-style-type: none"> 1. Review correct lighting procedures (see Figure 10 on page 15) 2. Adjust thermostat to "HI" position and check main burner ignition 3. Call your gas supplier. 4. Replace gas control valve .
Main burner won't stay lit.	<ol style="list-style-type: none"> 1. Gas control valve malfunctioning. 2. Broken thermostat bulb or capillary. 3. Improper seal at vent connections at rear of unit. 4. Blocked flue passageway. 5. Pilot orifice clogged. 6. Thermocouple not functioning. 	<ol style="list-style-type: none"> 1. Check the position of the gas control knob to knob frame. Remove front cover and check the movement of the gas control rod. Gas control valve may be jammed – repair or replace if needed. 2. Replace Gas Control Valve. 3. If exhaust vent kit was not cut and installed properly, pilot and main burner may not light. Repair or replace vent kit as needed. 4. Apply maintenance procedures (see SECTION IV of this manual) Eliminate blockage. 5. Apply maintenance procedures (see SECTION IV of this manual) or replace orifice. 6. Check thermocouple to insure it is connected properly and positioned on the center of the pilot flame tip. Replace if necessary.

SYMPTOM	POSSIBLE CAUSE	SOLUTION
	7. Improper gas supply.	7. Call your gas supplier.
Room will not maintain temperature.	1. Thermostat adjusted wrong . 2. Heater is too small for the heated space. 3. Excessive air leaks in room. 4. Broken or damaged thermostat bulb assembly. 5. Insufficient gas supply.	1. Adjust thermostat to "HI" position and modulate down until a proper room temperature rate is attained. 2. Average room size heating capacity: UNIT Ave. Floor Area Capacity CCV I up to 200 Sq Ft CCV II up to 400 Sq Ft CCV III up to 500 Sq Ft Obtain proper unit(s) for area to be heated. 3. Adequately close off and insulate your room to eliminate heat loss. 4. Replace Gas Control Valve. 5. Call your gas supplier.

SECTION VI

REPLACEMENT PARTS GUIDE
Orbis Calorama/Comfort View Series Gas System

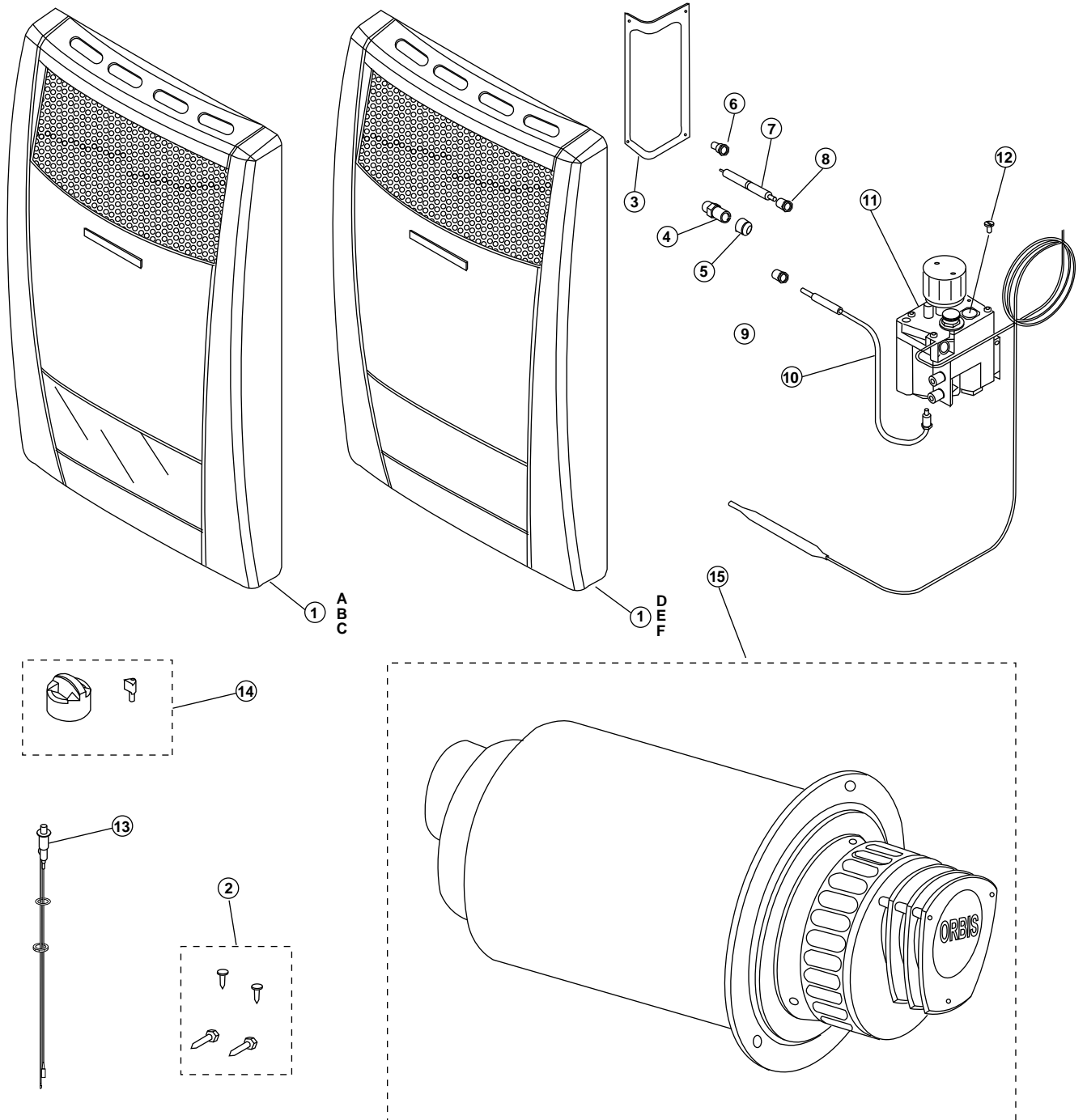

DIAGRAM NUMBER	DESCRIPTION OF PART	PART NUMBER
1 (A)	Front Cover Comfort View I	CCV - 1001
1 (B)	Front Cover Comfort View II	CCV - 2001
1 (C)	Front Cover Comfort View III	CCV - 3001
1 (D)	Front Cover Calorama I	CCV - 4001
1 (E)	Front Cover Calorama II	CCV - 5001
1 (F)	Front Cover Calorama III	CCV - 6001
2	Front Cover Fasteners Assembly	CCV - 5002
3	Main Burner support gasket	CCV - 5003
4 (A)	Main Burner Injector CCV I N. G. (\varnothing 1.22mm)	CCV -1004N
4 (B)	Main Burner Injector CCV I L P. (\varnothing 0.82mm)	CCV -1004P
4 (C)	Main Burner Injector CCV II N. G. (\varnothing 1.80mm)	CCV - 2004N
4 (D)	Main Burner Injector CCV II L P. (\varnothing 1.15mm)	CCV - 2004P
4 (E)	Main Burner Injector CCV III N. G. (\varnothing 2.10mm)	CCV - 3004N
4 (F)	Main Burner Injector CCV III L P. (\varnothing 1.35mm)	CCV - 3004P
5	Main Burner Injector Adaptor	CCV - 5005
6 (A)	Pilot Injector CCV N. G. (\varnothing 0.25mm 2x)	CCV -5006N
6 (B)	Pilot Injector CCV L. P. (0.20mm)	CCV - 5006P
7	Electrode Ceramic	CCV - 5007
8	Electrode Ceramic Fixing Nut	CCV - 5008
9	Thermocouple Fixing Nut	CCV - 5009
10	Thermocouple	CCV - 5010
11	Main Gas Valve N. G.	CCV - 5011N
11	Main Gas Valve L. P.	CCV - 5011P
12 (A)	Minimum Rate Screw, CCV I - N. G. (\varnothing 0.90mm)	CCV - 1012N
12 (B)	Minimum Rate Screw, CCV I - L. P. (\varnothing 0.70mm)	CCV - 1012P
12 (C)	Minimum Rate Screw, CCV II - N. G. (\varnothing 1.30mm)	CCV - 2012N
12 (D)	Minimum Rate Screw, CCV II - L. P (\varnothing 0.90mm)	CCV - 2012P
12 (E)	Minimum Rate Screw, CCV III - N. G. (\varnothing 1.70mm)	CCV - 3012N
12 (F)	Minimum Rate Screw, CCV III - L. P. (\varnothing 1.10mm)	CCV - 3012P
13	Piezoelectric Igniter Assembly	CCV - 5013
14	Knob Set (Piezo & Gas Valve)	CCV - 5014
15 (A)	Vent Kit, CCV I and CCV II	CCV - 5015A
15 (B)	Vent Kit, CCV III	CCV - 5015B

SECTION VII

Ten Year Limited Warranty

General

Orbis room heaters are warranted by the Manufacturer (Orbis-Mertig) through Gas Appliance Supply Co. Inc. (GASCO) and will repair or replace at ORBIS/GASCO's sole option any part which fails under normal use and service within the applicable periods specified below, in accordance with the terms of this warranty. The ORBIS/GASCO replacement will be warranted for the unexpired portion of the original warranty. This warranty will be valid only for room heaters in possession of the original purchaser as recorded on the warranty card.

Limited Five Year Warranty

1) GASCO will repair or replace – at its sole option – any part(s) which prove(s) defective in materials or workmanship within five (5) years of the original purchase date and owned by the Original purchaser, as verified by warranty card held on file at GASCO Corporate offices.
2) No liability is assumed by ORBIS/GASCO for removal or installation labor costs, nor for freight or delivery charges.

Limited Extended Warranty

1) In addition to the limited warranty, ORBIS/GASCO will replace any heat exchanger which fails under normal conditions of installation, use and service during a period of five additional years following the expiration of the five-year warranty. Replacement heat exchangers will be functionally similar and will be provided to the warranty holder of record as verified by card held on file at GASCO Corporate offices.

2) No liability is assumed by ORBIS / GASCO for removal or installation labor costs.

Shipping costs

In addition to supplying the replacement parts(s), GASCO will pay transportation costs for these parts to a convenient delivery point near you, selected by GASCO, such as a local, valid and current dealer or distributor.

Service labor costs

This warranty does not cover any labor costs associated with service, removal, or re-installation of part(s). All such costs must be borne by the Purchaser.

Exceptions

This warranty will not apply:

1. to defects or malfunctioning resulting from failure to properly install, operate or maintain the unit in accordance with the printed instructions provided;
 2. to damage or abuse, accident, neglect, or freezing and other acts of nature.
 3. to damage resulting from operation with the thermocouple removed.
 4. to failures of the heat exchanger resulting from the operation of the heater in a corrosive atmosphere;
 5. to defects or damage caused by any attachment or modification including any energy saving device.
- Note: The heater must not be subject to gas pressure greater than shown on the rating plate, which must not be altered, defaced, or removed.

How to make a claim

Any claim for warranty service should be made to your local dealer or distributor at the place of purchase. In most cases, the dealer or distributor will be able to promptly honor your claim and subsequently notify GASCO. However, all replacements are made subject to validation by ORBIS/GASCO of warranty coverage. The damaged or defective item MUST be made available in exchange for the replacement.

Miscellaneous

No one is authorized to make any warranties on behalf of ORBIS/GASCO. It is expressly understood that the replacement warranty of GASCO shall be in lieu of any and all other warranties, expressed or implied, including warranties of merchantability or fitness for a particular use or purpose, and further that GASCO shall not be liable for any loss or damage directly or indirectly arising from the use of the heater, or for any consequential damages arising from such use (including damages from water).

GASCO's liability with the respect to any defect shall be for the replacement of the defective part(s). Some states do not allow such limitations and exclusions, so the above may not apply to you.

This warranty gives specific legal rights. You may also have other rights which vary from state to state. In the event that warranty service is required, reasonable proof of the effective date of installation and operation must be provided.

FOR TECHNICAL ASSISTANCE OR TO PLACE AN ORDER
FOR REPLACEMENT PARTS,
PLEASE CONTACT YOUR GAS SUPPLIER / SERVICE TECHNICIAN OR
APPLIANCES, SERVICES AND PARTS COMPANY,
INC [ASAP] (INFORMATION BELOW)

MANUFACTURED BY:

ORBIS MERTIG SAIC
YERBAL 1200
1607 VILLA ADELINA
PROVINCIA DE BUENOS AIRES
ARGENTINA



IMPORTED BY:

THE GAS APPLIANCE SUPPLY CO., INC. (GASCO)
FLORIDE, US of A

INTERNET ADDRESS: www.orbisheat.com

EMAIL: info@orbisheat.com

SECTION VIII

BLOWER OPTION

You can use an optional blower kit with your heater and can be ordered thru your dealer. This kit can improve heat circulation in the room in which you installed your Calorama/Comfort View unit.

Installation instructions:

Remove the unit's front cover to access the mounting point of the Temperature Activation Sensor on the upper right side of the unit, above the gas valve. (See figure 13). With the cover still off, mount blower into the wall directly under and centered on the unit using the two fastening screws provided. (See figure 12 for the correct installation distances).

Mount the temperature activation sensor at place provided for. (See figure 13). Replace the unit front cover. Plug in the blower assembly and turn rotating switch to activate.

Note: The blower will not respond until the unit is working for about 8 minutes and has reached the operating temperature.

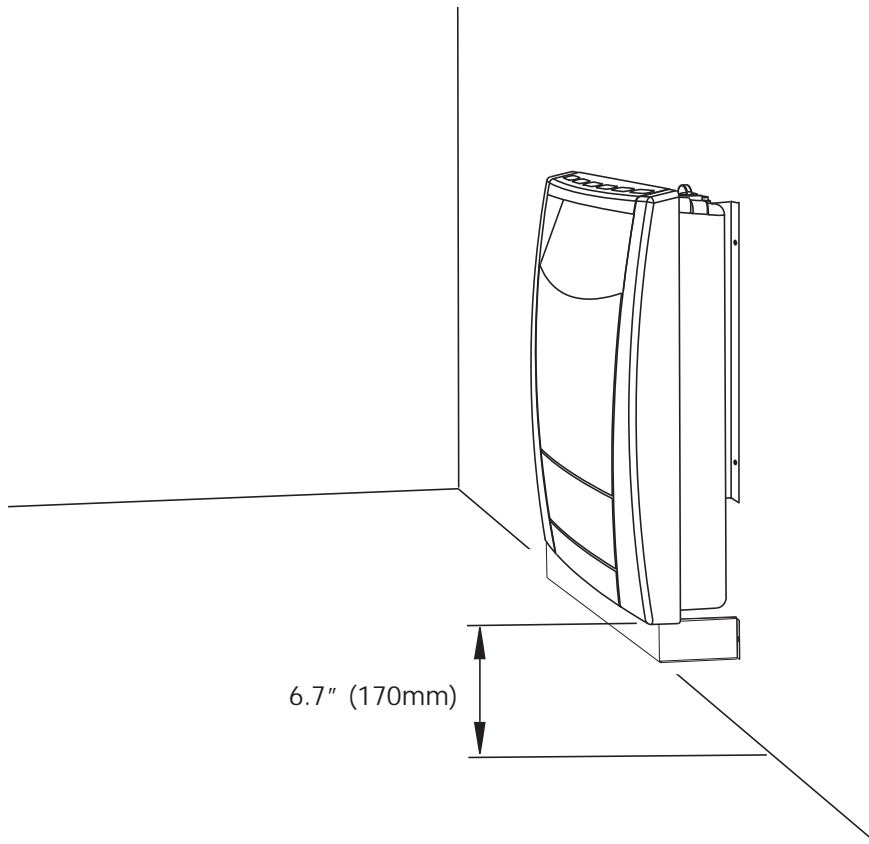

Figure 12: Blower Installation

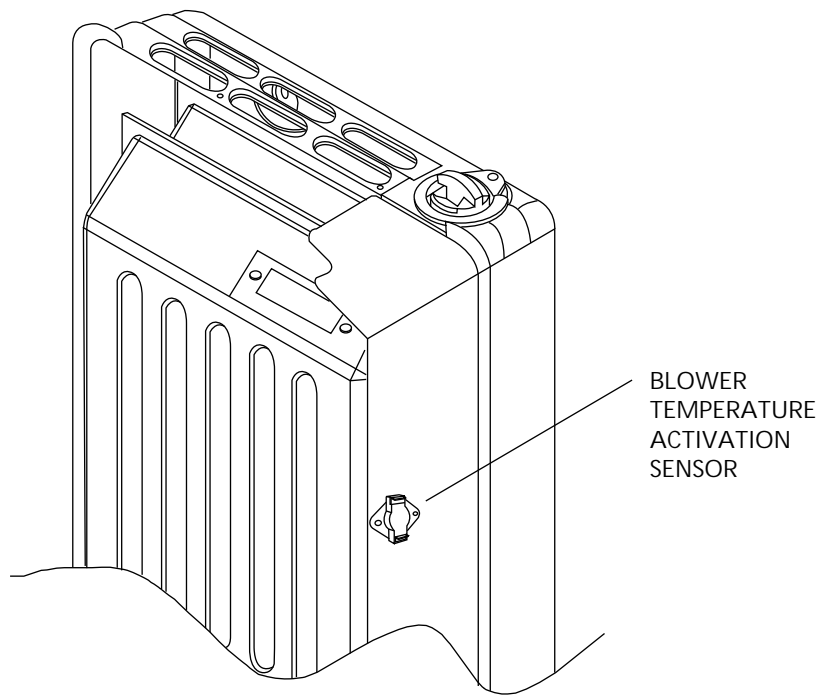

Figure 13: Blower Temperature Activator Sensor Installation

REPLACEMENT BLOWER PARTS GUIDE

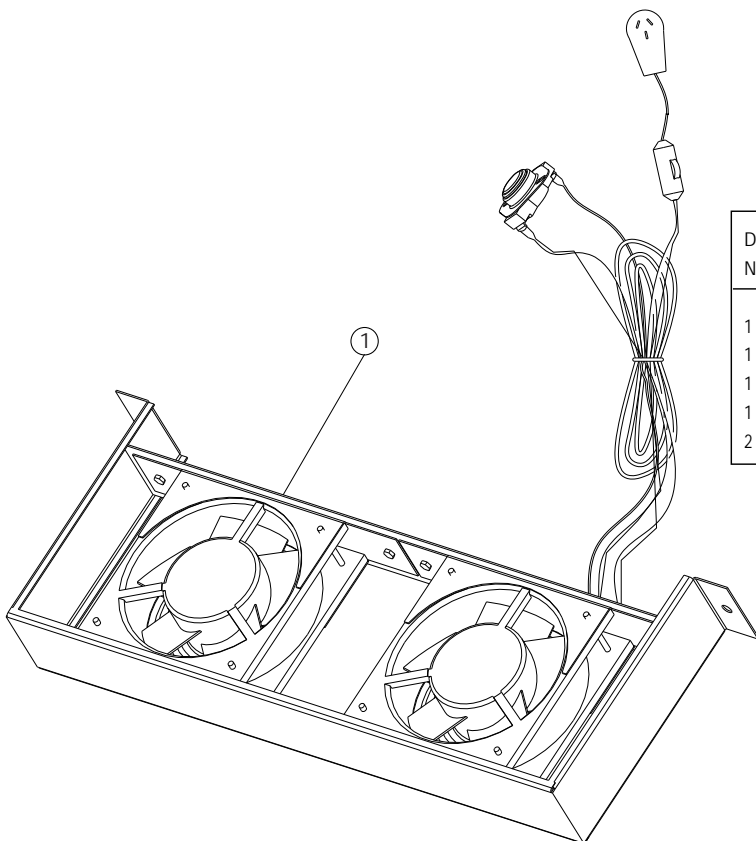

DIAGRAM NUMBER	DESCRIPTION OF PART	PART NUMBER
1 (A)	Blower kit Calorama/Comfort View I	BK - 1
1 (B)	Blower kit Calorama/Comfort View II	BK - 2
1 (C)	Blower kit Calorama/Comfort View III	BK - 3
1 (D)	Blower Fan (All Units)	BK - Fan
2	Blower Temperature Activation Sensor	BK - TS1

76H00172 Rev. 3/02